

FG-M GAS FLOW MONITOR

TECHNICAL CHARACTERISTICS:

- ✓ Dial rotates 270° horizontally
- ✓ Thermal conduction principle works
- ✓ Supports quick selection of monitoring media
- ✓ Provide digital interfaces and communication protocols
- ✓ Provides a variety of rated flow range options
- ✓ 3-digit digital tube display, easy to read measurement results



Gas flow monitors are widely used in various industries and application scenarios, such as industrial control (kilns), environmental monitoring, medical equipment and laboratory research. Gas flow monitors can provide reliable gas flow measurement solutions.

The gas flow monitor uses MEMS flow sensing chip technology to measure the gas medium flow in the flow channel through the principle of thermodynamics. It adopts precise measurement technology and fast-response sensors. The gas flow monitor can provide highly accurate flow measurement results and can operate stably even under complex environmental conditions. In addition, we also provide digital interfaces and remote monitoring functions to help customers easily obtain real-time data and perform remote configuration and control.

APPLICATIONS:

- ◇ Smart building
- ◇ Smart factory
- ◇ Laboratory
- ◇ Environmental monitoring

TECHNICAL PARAMETERS:

Product Number	FG-M
Measuring Medium	Air, nitrogen, hydrogen, oxygen
Medium Temperature	-10~60° C
Detection Method	Thermal
Rated Flow Range	100/300/400/800/1000 (unit SLM)
Range Ratio	50:1
Pressure Resistant	Maximum 0.2~2MPa (determined according to flow range)
Voltage	DC24V
Accuracy	± 2%FS
Unit	L/min(customized)
Output Method	4~20mA/RS485
Outgoing Method	Straight out, Aviation
Installation Method	PT1/2 external thread, PT3/4 external thread, etc. (determined according to flow range)
Shell Material	Polyester plastic
Base Material	Aluminum alloy

DIMENSION:

UNIT:mm

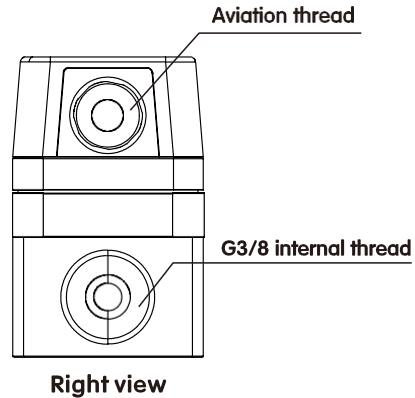
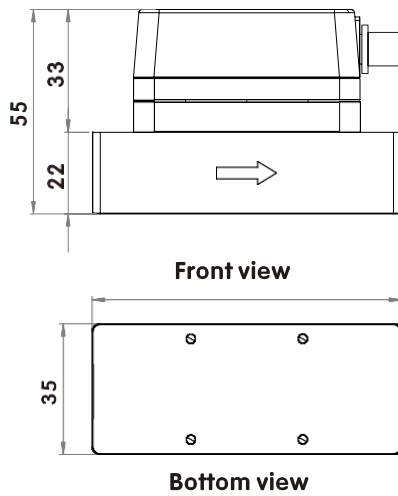

Note: The example of G3/8 female thread and aviation plug connector outlet is used as an illustration.

Applicable pipe inner diameter(mm)	Dimensions(mm)	Range(SLM)	Installation Method
8~12	83*35*55	100	G3/8 internal thread
8~12	119*35*55	300	PT1/2 external thread
12~15	92*35*55	400	PT1/2 external thread
19~25	92*35*55	800	PT3/4 external thread
32~36	128*50*83	1700	PT1-1/4 external thread

SELECTION GUIDE:

FG-M - 300 - 2 - AIR - 4 - 1 - M2 - S - 60

<p>Model: FG-M</p> <p>Range: 100(100SLM) 300(300SLM) 400(400SLM) 800(800SLM) 1700(1700SLM)</p> <p>Accuracy 2 (2%FS)</p> <p>Measuring Medium: AIR(Air) H₂(Hydrogen) O₂(Oxygen) N₂(nitrogen)</p> <p>Output Signal: 4 (4~20mA) R(RS485)</p> <p>Notes:</p>	<p>Measurement Temperature 60 (-10-60°C)</p> <p>Outgoing method: S (Straight out) A (Airline-plug)</p> <p>Installation Method: G3 (G3/8 female thread) M2 (PT1/2 male thread) M3 (PT3/4 male thread) M14 (PT1-1/4 male thread)</p> <p>Power supply: 1 (24V)</p>
---	---

1. This selection manual uses the flow unit under gas standard conditions (volume conversion flow display at 20° C, 1 atm atmospheric pressure).
2. If the use situation requires prohibiting copper or zinc materials, please select the straight outlet form in the outlet method.
3. The installation method of the sensor is determined according to the corresponding usage range.
4. The default medium is air and nitrogen. If you need different gases, please customize them.