

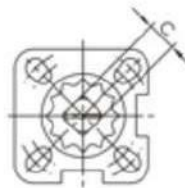

### 2-pc Flange Ball Valve

- Investment casting for body and cap
- Full bore
- Flanged ends: ANSI B16. 5
- Face to Face: ANSI B16. 10
- Mounting Pad: ISO5211
- Pressure rating : 150 Lb
- Working temperature: -25°C +180°C
- Material: CF8M, CF8, CF3M, WCB

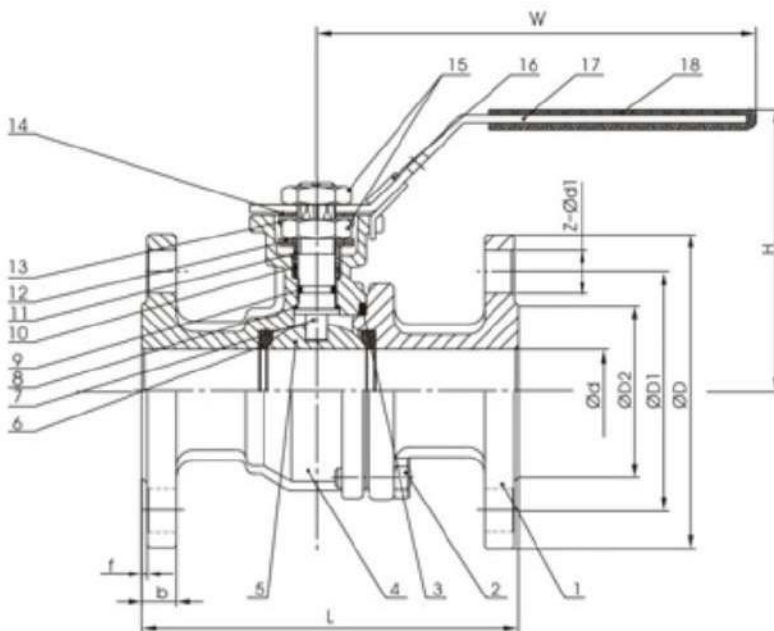

ISO5211

### DIMENSION LIST

SIZE	d	L	D	D1	D2	b	f	H	W	C	ISO5211	Z-Ød1	N•m	Kgs
1/2"	15	108	89	60.5	35	10	2	80	140	9	F03/F04	4-Ø16	5	1.35
3/4"	20	117	98	70	43	11	2	85	140	9	F03/F04	4-Ø16	8	1.85
1"	25	127	108	79.5	51	11	2	95	160	11	F04/F05	4-Ø16	10	2.60
1-1/4"	32	140	117	89	64	13	2	108	160	11	F04/F05	4-Ø16	14	3.58
1-1/2"	38	165	127	98.5	73	15	2	114	185	14	F05/F07	4-Ø16	18	5.40
2"	50	178	152	120.5	92	16	2	124	185	14	F05/F07	4-Ø19	25	7.95
2-1/2"	65	190	178	139.5	105	18	2	148	230	17	F07/F10	4-Ø19	48	13.50
3"	76	203	190	152.5	127	19	2	158	230	17	F07/F10	4-Ø19	75	17.30
4"	94	229	229	190.5	157	24	2	191	230	17	F07/F10	8-Ø19	110	29.50

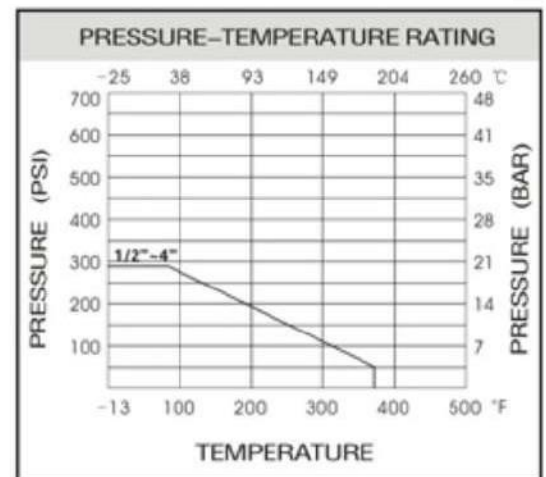

### MATERIAL LIST

ITEM	PART	MATERIAL	QTY
1	Cap	CF8M	1
2	Bolt	SS304	4 (8)
3	Body Gasket	PTFE	1
4	Body	CF8M	1
5	Ball	SS316	1
6	Ball Seat	R-PTFE (15%)	2
7	Stem	SS316	1
8	Thrust Washer	PTFE	1
9	O-ring	VITON	1
10	Stem Packing	PTFE	1
11	Packing Ring	SS304	1
12	Belleville Washer	SS301	2
13	Nut Stopper	SS304	1
14	Plate Washer	SS304	1
15	Nut	SS304	2
16	Lock Device	SS304	1
17	Handle	SS304	1
18	Plastic Cover	Plastic	1
19	Stop Pin	SS304	1