

SINTEK

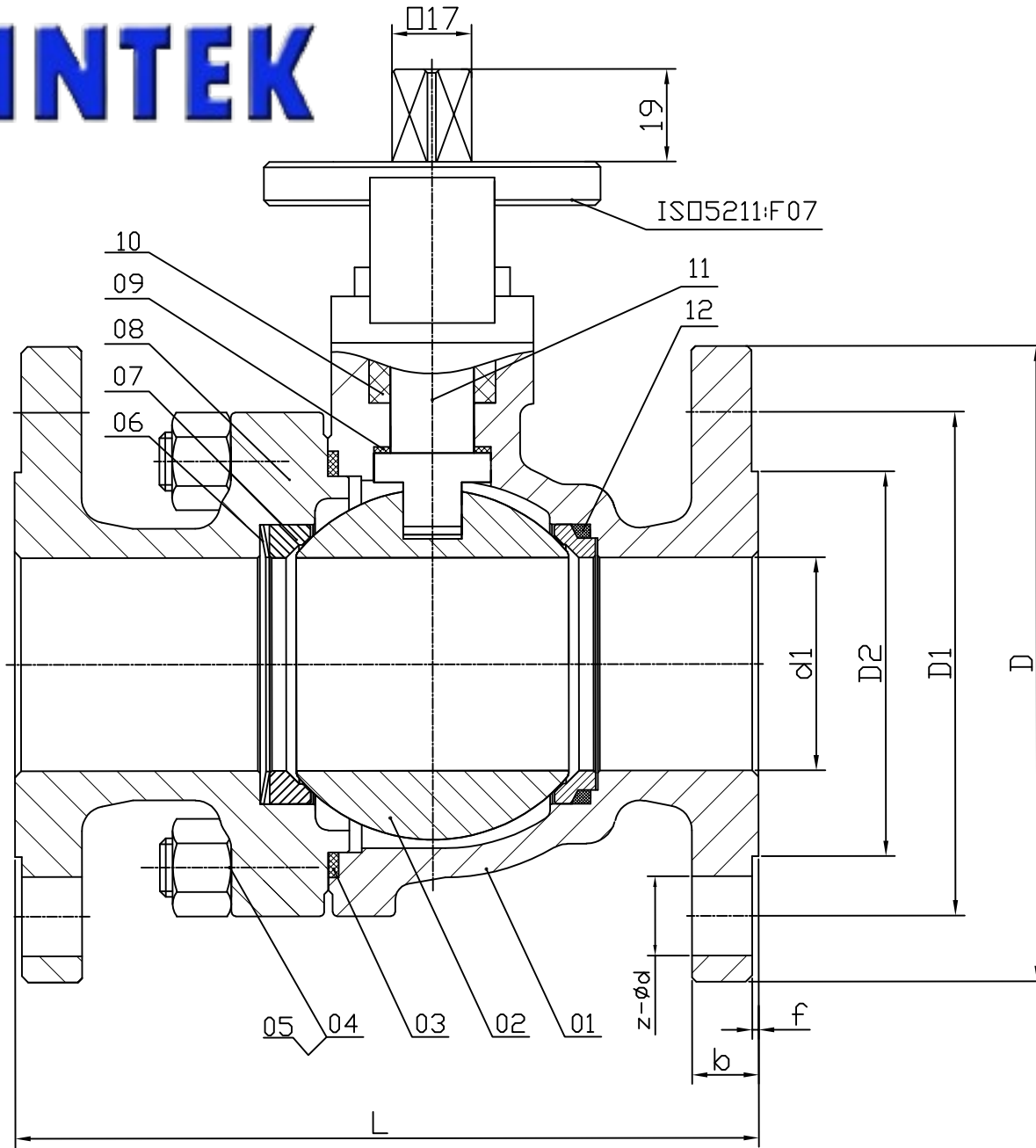

CLASS	PRESSURE TEST (MPa)		
	SHELL TEST	SEAT TEST	AIR TEST
150LB	3.0	2.2	0.6
APPLICABLE TEMPERATURE			-29~350℃

1. DESIGN AND MANUFACTURE	API 6D
2. FACE TO FACE DIMENSIONS	ASME B16.10
3. FLANGE ENDS DIMENSIONS	ASME B16.5
4. FIRE SAFE	API 607
5. PRESSURE TEST	API 598

CLASS	SIZE	d1	L	D	D1	D2	f	b	z-φd
150LB	1"	25	127	110	79.4	50.8	2	11.6	4-16
150LB	1½"	38	165	125	98.4	73.0	2	14.7	4-16
150LB	2"	50	178	150	120.7	92.1	2	16.3	4-19

12	GRAPHITE RING	GRAPHITE
11	STEM	A182-F304
10	PACKING	GRAPHITE
9	THRUST WASHER	304+N
8	BONNET	A351-CF8
7	SEAT	A182-F304+Ni55
6	SPRING	17-7PH
5	STUD	A193-B8
4	NUT	A194-8
3	GASKET	304+GRAPHITE
2	BALL	A182-F304+Ni60
1	BODY	A351-CF8
NO	PART NAME	MATERIAL

DATE	TAG NO.:	000000
VENDOR DOC. NO.:	SCALE:	
Δ	DRAWN	DATE
Δ	CHECKED	DATE
REV. NO.	DESCRIPTION	APPROVED
		DATE