

### PDS2

### DIGITAL PRESSURE GAUGE

#### TECHNICAL CHARACTERISTICS:

- ✓ The dial can be rotated 330°
- ✓ Large LCD screen, support multiple unit switching
- ✓ Support reset, backlight, Bluetooth connection, APP collection and other functions
- ✓ Low power consumption design, 2 AA batteries, 12 months of battery life
- ✓ Beautiful appearance, the whole shell is covered with rubber, with delicate feel



PDS2 is a digital pressure gauge with a built-in high-precision pressure sensor, which can accurately display the pressure in real time, and has the characteristics of high precision and good long-term stability.

This digital pressure gauge is equipped with a large-size LCD liquid crystal display, which has multiple functions such as zero reset, backlight, power on and off, unit switching, low voltage alarm, etc. It is easy to operate and install. The dial orientation can be rotated 330° , which is convenient for customers to read from the desired angle. The equipment product adopts the whole casing to be covered with rubber, which has good shock resistance and can measure gas, liquid, oil and other media that are not corrosive to stainless steel. This series of products supports Bluetooth applets and APP configuration parameters, including: pressure value display, acquisition rate modification, reset operation and other settings.

PDS2 digital pressure gauge is suitable for portable pressure measurement, equipment matching, calibration equipment and other pressure measurement fields.

#### APPLICATIONS:

- ◇ Machinery and electronic industry
- ◇ Supporting equipments of instruments
- ◇ Pressure laboratory
- ◇ Mechanical engineering automation
- ◇ Replacement of pointer pressure gauge

#### TECHNICAL PARAMETERS:

|                       |   |
|-----------------------|---|
| Range                 | Negative/compound pressure: -0.1~0...0.1...1.6MPa<br>Differential pressure: 0~10..40...60kPa<br>Normal pressure: 0~0.1...1.0...6MPa<br>High Pressure: 0~10...25...60MPa |
| Overload Capacity     | 200%FS  |
| Color                 | White   |
| Dimension             | 143.5*75*40.5mm   |
| ACC                   | 0.5%FS<br>0.2%FS  |
| Long-term Stability   | Typical ± 0.3%FS/year   |
| Operating Temperature | -20 ~ 65°C  |
| Electrical Protection | Anti-electromagnetic interference design  |
| Measuring medium      | Oil, water, gas and other stainless steel corrosion free medium pressure  |
| Connection            | M20*1.5, G1/4 or customized   |
| Connection material   | 304 stainless steel   |
| Shell material        | TPE+ABS   |
| Product features      | Turn on/off backlight clear zero unit switch extreme value record Bluetooth connection  |
| Power supply voltage  | 3V (2 AA batteries)   |
| Power display         | Four sections display   |
| Dial                  | Can rotate the dial at 330 degrees  |
| Pressure unit         | MPa, bar, kgf、mH2O、PSI、kPa、mmHg、mBAR、mmH2O、Pa、inWC  |

### DIMENSION:

UNIT:mm

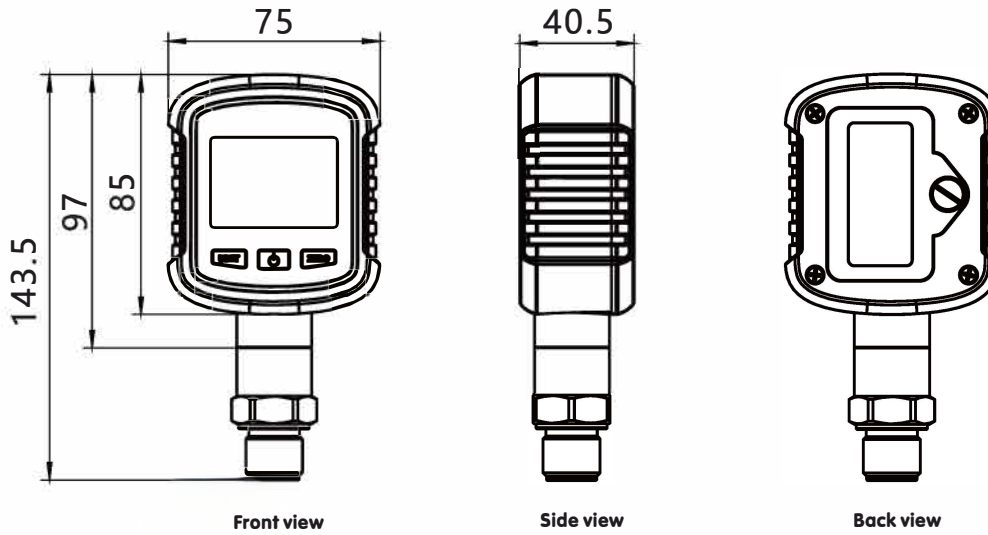

### SELECTION GUIDE:

